

Clarion

Owner's manual
Mode d'emploi
Bedienungsanleitung
Manuale di istruzioni
Gebruiksaanwijzing
Manual de instrucciones
Bruksanvisning
Manual de instruções

DVH943

5.1CH SURROUND DECODER

•
DÉCODEUR SURROUND 5.1 CANAUX

•
5.1-KANALIGER SURROUND-DECODER

•
DECODIFICATORE DI SUONO AVVOLGENTE A 5.1 CANALI

•
5.1-KANAALS SURROUND-DECODER

•
DESCODIFICADOR DE 5.1CH SURROUND

•
5.1CH SURROUND LJUDSDEKODER

•
DESCODIFICADOR SURROUND 5.1 CANAIS

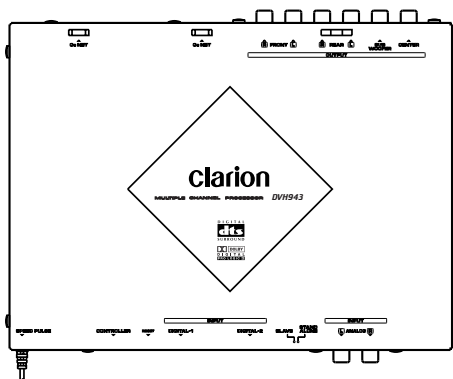

Thank you for purchasing the **Clarion** product.

- * Please read this owner's manual in its entirety before operating this equipment.
 - * After reading this manual, be sure to keep it in a handy place (e.g., glove compartment).
 - * Check the contents of the enclosed warranty card and keep it carefully with this manual.
 - * The DVH943 can be operated by the CeNET-compatible Clarion Centre Units.
- These operating instructions note functions which change as the result of connecting the DVH943 to one of the above components.

Contents

1. PRECAUTIONS	2
2. FEATURES	3
3. SPECIFICATIONS	4
4. CONFIRM BEFORE OPERATION	5
5. OPERATIONS	7
Operations (DXZ748RMP)	7
Setting Acoustic Features	8
6. WIRING TECHNIQUES	11
Name of Parts	11
How to Wire This Unit	12
7. INSTALLATION	13
Installation Precautions	13
Installation Example (for installation beneath seat)	13
8. SYSTEM EXPANSION	14
9. IN CASE OF DIFFICULTY	16

1. PRECAUTIONS

1. The DVH943 can easily be damaged by moisture, high temperatures or high humidity. Keep the inside of the car clean and well ventilated.
2. Never subject the DVH943 to strong shocks or open its case. Doing so may result in damage.
3. Use a soft, dry cloth to wipe dirt off the DVH943. Never use a hard cloth or thinner, alcohol, etc. For tough dirt, apply some cold or lukewarm water to a soft cloth and wipe off the dirt gently.
4. When the main unit is switched to the traffic announcement or PTY interrupt reception while using the DVH943, the effect from DVH943 doesn't work.
5. Some tracks may sound distorted when adjustment; this is normal and not a cause for concern.

⚠ CAUTION

CHANGES OR MODIFICATIONS NOT EXPRESSLY APPROVED BY THE MANUFACTURER FOR COMPLIANCE COULD VOID THE USER'S AUTHORITY TO OPERATE THE EQUIPMENT.

INFORMATION FOR USERS:

CHANGES OR MODIFICATIONS TO THIS PRODUCT NOT APPROVED BY THE MANUFACTURER WILL VOID THE WARRANTY.

2. FEATURES

■ **Onboard DTS/Dolby Digital/Pro Logic II Decoder**

- Independent playback of DVD video surround format DTS, Dolby Digital 5.1ch.
- Utilizes Pro Logic II with advanced digital matrix technology for 5.1 channel decoding of 2-channel CD and radio.

■ **Newly developed 32-bit DSP LSI with advanced processing performance**

- DSF function allows application of 6 sound field effect patterns following decoding of DTS, Dolby Digital 5.1ch format, or Dolby Pro Logic II signals.
- The parametric equalizer function allows you to adjust the frequency characteristics to suit the car.

■ **High precision 96 kHz / 24 bit D/A converter used in all channels**

■ **New-type digital input connectors**

- New digital input connectors support sampling rate of 96 kHz.
32 kHz: MP3 etc.
44.1 kHz: CD, CD-R, CD-RW, MD
48 kHz: DVD video
96 kHz: DVD video

■ **Supports analog input connectors (RCA 2ch) (when optional control unit is connected)**

- When centre unit or other RCA 2ch output is connected to analog input connectors, Dolby Pro Logic II function can convert to 5.1ch output.

■ **Thin-line chassis can be installed beneath seat.**

■ **DTS**

- DTS (Digital Theater System) is an audio compression technology developed by Digital Theater Systems, Inc. Its low compression ratio provides a higher quantity of data and thus higher quality sound.
- * Manufactured under license from Digital Theater Systems, Inc. US Pat. No. 5,451,942, 5,956,674, 5,974,380, 5,978,762 and other world-wide patents issued and pending. "DTS" and "DTS Digital Surround" are registered trademarks of Digital Theater Systems, Inc. © 1996, 2000 Digital Theater Systems, Inc. All Rights Reserved.

■ **Dolby Pro Logic II**

- Using the newest in digital matrix technology, Dolby Pro Logic II is a matrix decoder technology which further improves earlier Dolby Pro Logic. This new technology produces superb 5.1ch sound even with CDs and other stereo sources.
The surround channel is converted to full-band (20 Hz-20 kHz) stereo, thus allowing stereo sources to be enjoyed with the impact of 5.1ch sound. Four modes can be set in accordance with the playback source, including MUSIC mode, MATRIX mode, MOVIE mode, and VIRTUAL mode.
- Dolby Digital is a totally discrete digital 5.1 channel format. Signals for the front 3 channels, 2 surround channels, and the low-frequency 0.1 channel are recorded discretely, so no crosstalk occurs between channels, and the sense of placement and depth of the sounds is reproduced faithfully.
- * Manufactured under license from Dolby Laboratories.
"Dolby", "Pro Logic" and double-D symbol are trademarks of Dolby Laboratories.

3. SPECIFICATIONS

Digital/Analog Processing Section

Frequency response:
 20 Hz - 44 kHz (Linear PCM 96 kHz)

S/N ratio:
 95 dB or more
 (IHF-A, sound-field effects OFF)

Separation:
 80 dB or more (with digital input)

Total harmonic distortion:
 0.01% or less (with digital input)

Analog output / impedance:
 4 V / 330 Ω (6ch output)

DSP/EQ section

DSF:
 6 patterns

P.EQ functions

Band:
 3-band × 3 ch (centre, front, surround)

F (central frequency):
 20 Hz - 20 kHz (1/3 octave step, 31 points)

Q curve:
 1 - 20 (5 points)

Gain:
 ±12 dB

General

Power supply:
 DC 14.4 V (10.8 - 15.6 V)

Ground:
 Negative ground

Power consumption:
 480 mA

Dimensions:
 230 (W) × 25 (H) × 170 (D) mm

Weight:
 900 g

Note:
 • Specifications and design are subject to change without notice for further improvement.

List of accessories

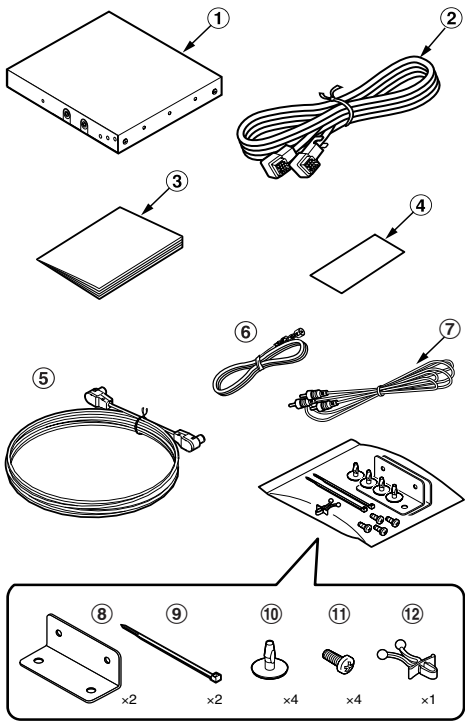

① DVH943	1
② CeNET cable (5 m)	1
③ Owner's manual	1
④ Warranty	1
⑤ Optical Digital Cable (5 m)	1
⑥ Speed pulse extension Cable (5 m)	1
⑦ RCA PIN Cable (5 m)	1
⑧ Mounting brackets	2
⑨ Cord clamps	2
⑩ Canoe clips	4
⑪ Mounting screws	4
⑫ Cable Clip	1

4. CONFIRM BEFORE OPERATION

This component does not operate independently as a stand-alone unit and must be used in conjunction with an operational Clarion Source Unit (CeNET supported), or a 5.1 CH surround decoder control unit (DVC923).

See section "8. SYSTEM EXPANSION" (P. 14) for details regarding other compatible components.

■ **CeNET Cable**

The CeNET cable used must not be over 20 m long (including the length of the CeNET branch cable CCA-519). When making connections be sure that your cable length is not over 20 m.

■ **Optical Digital Cables (sold separately or furnished)**

Optical digital cables (sold separately or furnished) connected to this unit differ depending on the model of CeNET component involved.

Consult your dealer regarding the kind of optical digital cable required for your component.

Likewise, consult the operating instructions accompanying your component for details regarding connections.

CeNET connections

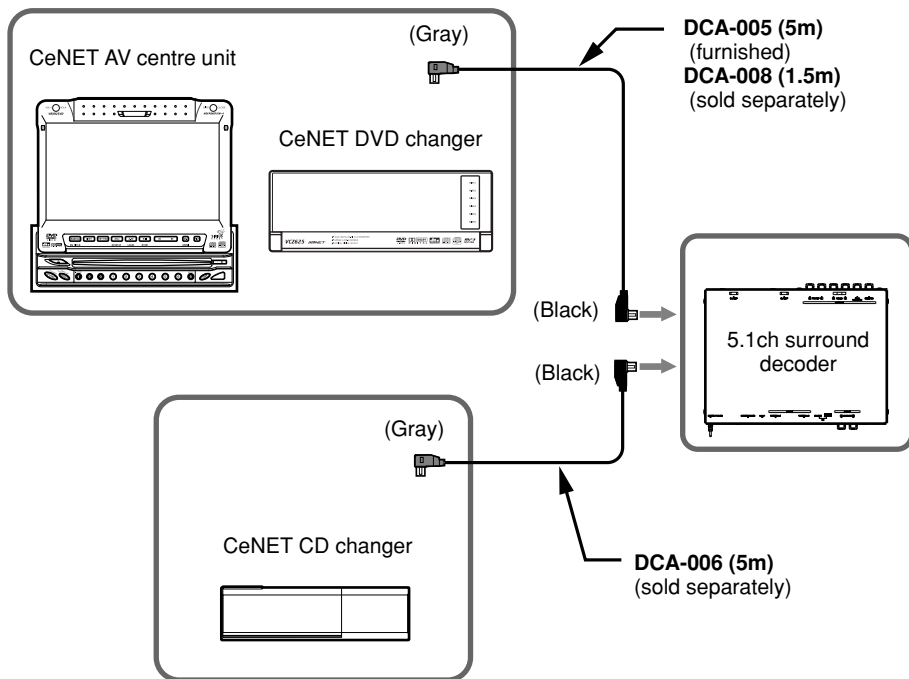

Speaker System

- To get maximum enjoyment from the sound-field functions of this component, the use of a 5.1ch speaker system is recommended. To demonstrate optimum audio response, modify the adjust mode's default settings for "SP-SEL," "FILTER," "SP-GAIN," and "DELAY" in accordance with the composition of your speaker system (see P.8-10).
Note that in order to play 2-ch sound sources (music CDs, etc.) in 5.1ch mode, one of the Dolby Pro Logic II modes must be selected, or DSF must be set to ON (see P. 7).

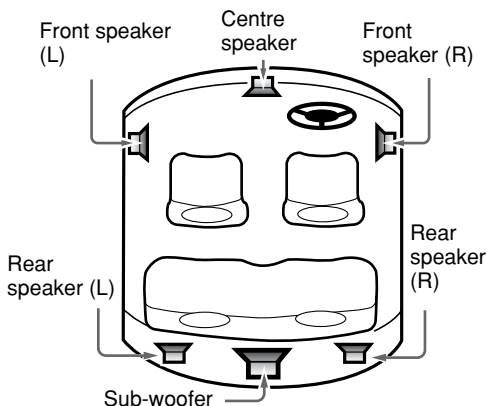

DVD Video

- When playing a DTS-compatible DVD video or music CD, some noise may be heard for the short interval required for this unit to detect the DTS signal.
- During playback of Dolby digital or DTS source, some sound interruption may be heard if the search/skip/pause modes are operated before playback.

Digital Inputs (When Optical Digital Cable is Connected)

- When optical digital cable is used to connect components like a DVD changer, the digital signals are given precedence in processing.
- When Dolby Digital (other than 2ch), DTS, Linear PCM (96 kHz) or other digital signals are input, the Dolby Pro Logic II mode can be selected, but the mode will not perform ordinary audio processing.
- When MP3 (32 kHz) and Linear PCM (96 kHz) digital signals are input, the Parametric Equalizer (PEQ) function can be operated, but it will not perform audio processing.

Sound Effects and Sound-Field Compensation with Digital and Analog Signals

Input Signal	Sampling Rate	Recording Format	Recording channels	PLII function	DSF function	P.EQ function
Digital signals	fs=32 kHz	MP3 etc.	2ch	O	O	×
	fs=44.1 kHz	CD-DA	2ch	O	O	O
		Linear PCM	2ch	O	O	O
	fs=48 kHz	Dolby Digital	2ch	O	O	O
			(Not 2ch)	×	O	O
		DTS	2ch~5.1ch	×	O	O
fs=96 kHz	Linear PCM	2ch	×	O	×	
Analog signals	—	—	2ch	O	O	O

O: Adjustable ×: Adjustable without audio processing
(Analog signals: when connected to CeNET connectors or analog input connectors)

5. OPERATIONS

Operations (DXZ748RMP)

Dolby Pro Logic II Menu Selection

About the Dolby Pro Logic II Mode

- Initial setting is [PL II OFF].
 - **MUSIC mode**
 - Suitable for CDs and other stereo sources.
 - **MATRIX mode**
 - Suitable for AM/FM radio sources.
 - **MOVIE mode**
 - Suitable for DVD video movies.
 - **VIRTUAL mode**
 - Suitable for movies and other audio sources.
- 1. Press the [ADF] button to enter PLII mode.
- 2. Press the [◀] or [▶] button to select PLII. [MUSIC] → [MATRIX] → [MOVIE] → [VIRTUAL] → [PLII OFF]
- 3. Press the [ADF] button to return to the original mode.

Notes:

- The PL II menu cannot be selected when [SP-SEL] has been used to set centre speakers and rear (surround) speakers to [OFF].
- Sound is produced from the centre speaker only when either Dolby Pro Logic II mode, or DSF mode is set to ON (2-channel source playback).

DSF Setting

DSF(Digital Sound Field) makes it possible through sound simulation to enjoy the acoustic experience you would have in a concert hall or a live performance hall.

- Initial setting is [OFF].
- 1. Press the [ADF] button to enter DSF mode.
- 2. Press the [◀] or [▶] button to select DSF menu.
 - ① **HALL**: Large concert hall.
 - ② **CHURCH**: Church with a vaulted ceiling.
 - ③ **STADIUM**: Large stadium without roof or walls.
 - ④ **LIVE**: Live performance hall, larger than a jazz club.
 - ⑤ **JAZZCLUB**: Jazz club with a low ceiling.
 - ⑥ **THEATER**: Movie or drama theater.
 - ⑦ **OFF**: DSF off.
- 3. Press the [ADF] button to return to the original mode.

Setting parametric equalizer (P.EQ)

The parametric equalizer function allows you to adjust the frequency characteristics to suit the car.

- The initial value provides the following settings for all speakers.
FREQ = 1kHz, Q = 1, GAIN = 0dB
 - Some distortion may be heard if the [ROTARY] knob is turned rapidly.
1. Press and hold the [ADJ] button for 1 second or longer to enter adjust mode.
 2. Press the [◀] or [▶] button to change to the [P.EQ E] display.
 3. Press the [ENT] button to display the adjustment item.

Press the [◀] or [▶] button to select [EFFECT], [SIGNAL], [SP-SEL], [BAND], [FREQ], [Q], [GAIN] or [SIGNAL].

- **EFFECT**: P.EQ effect is turned on or off.
 - Initial setting is [OFF]
- **SIGNAL**: selects the adjustment signal.
 - **SGNL P-NOIS**: set when pink noise is to be used
 - **SGNL MUSIC**: set to use music signals
- **SP-SEL**: selects the speakers whose P.EQ value is to be adjusted.
 - **SP FRONT**: front speaker
 - **SP CENTER**: centre speaker
 - **SP SURROUND**: surround speaker
- **BAND**: selects the frequency band (Band 1 to 3) to adjust.
- **FREQ**: selects the frequency for bands 1 to 3.
 - The range of adjustments is from 20 Hz to 20 kHz.
- **Q**: sets the Q curve.
 - Larger numbers produce a sharper Q characteristics curve while smaller numbers produce gentler characteristics. Adjustments are made in the range Q1 to Q20.
- **GAIN**: adjusts the output level.
 - Adjustments are made in the range -12 dB to +12 dB.

4. Turn the **[ROTARY]** knob clockwise or counterclockwise to adjust each value.
5. Press the **[ADJ]** button to return to the original mode.

Setting Acoustic Features

Turning speakers on or off (SP-SEL)

The centre speaker, rear (surround) speakers and sub woofer have to be set to on or off to achieve maximum sound quality.

- The initial setting is **[ON]**.
1. Press and hold the **[ADJ]** button for 1 second or longer to enter adjust mode.
 2. Press the **[◀◀]** or **[▶▶]** button to change to the **[SP-SEL ■]** display.
 3. Press the **[ENT]** button to display the adjustment item.
Press the **[◀◀]** or **[▶▶]** button to select **[CENTER-SP]**, **[SURROUND-SP]** or **[SUB-WOOFER]**.
 - **CENTER-SP**: centre speaker
 - **SURROUND-SP**: rear (surround) speaker
 - **SUB-WOOFER**: subwoofer
 4. Turn the **[ROTARY]** knob clockwise or counterclockwise to select **[ON]** or **[OFF]**.
 - **ON**: Speaker installed
 - **OFF**: Speaker not installed
 - When a sub woofer is used, set **[ON+]**, **[ON-]** or **[OFF]**. The normal setting is **[ON+]**, but use the **[ON-]** setting when this provides a better effect for low frequency range.
 5. Press the **[ADJ]** button to return to the original mode.

Setting speaker filter frequency (FILTER)

This function is used to set a filter frequency that suits the frequency characteristics of the used speakers.

- The initial value of **[FRONT HPF]**, **[SRD HPF]** is **[THRGH]** (no filter).
 - The initial value of **[CENTER HPF]**, **[SUB-W LPF]** is **[120 Hz]**
 - A speaker that was turned off in the Section "Turning speakers on or off (SP-SEL)" is not displayed.
1. Press and hold the **[ADJ]** button for 1 second or longer to enter adjust mode.
 2. Press the **[◀◀]** or **[▶▶]** button to change to the **[FILTER ■]** display.
 3. Press the **[ENT]** button to display the adjustment item.

4. Press the [◀] or [▶] button to select the speaker to adjust.
 - **FRONT HPF**: high pass filter for front speakers
 - **CENTER HPF**: high pass filter for the centre speaker
 - **SRD HPF**: high pass filter for the rear (surround) speakers
 - **SUB-W LPF**: low pass filter for the subwoofer
5. Turn the [ROTARY] knob clockwise or counterclockwise to select the frequency.
 - In case of [FRONT HPF] and [SRD HPF], the frequency is 50 Hz, 80 Hz, 120 Hz and [THRGH] (no filter).
 - In case of [SUB-W LPF], [CENTER HPF] the frequency is 50 Hz, 80 Hz or 120 Hz.
6. Press the [ADJ] button to return to the original mode.

Adjusting speaker output level (SP-GAIN)

Use the built-in test tone function of the unit to adjust the speaker output level to the same level.

- The initial value is [0 dB].
 - A speaker that was turned off in the Section “Turning speakers on or off (SP-SEL)” is not displayed.
1. Press and hold the [ADJ] button for 1 second or longer to enter adjust mode.
 2. Press the [◀] or [▶] button to change to the [SP-GAIN **E**] display.
 3. Press the [ENT] button to display the adjustment item.
 - In the adjustment mode, the test tone is output from the selected speaker.
 4. Press the [◀] or [▶] button to select the speaker to adjust.
 - **FRONT-L**: front left speaker
 - **CENTER**: front centre speaker
 - **FRONT-R**: front right speaker
 - **SURROUND R**: right rear (surround) speaker
 - **SURROUND L**: left rear (surround) speaker
 - **SUB-WOOFER**: rear subwoofer
 5. Turn the [ROTARY] knob clockwise or counterclockwise to adjust the gain.
 - The adjustment range is -10 dB to +10 dB.
 6. Press the [ADJ] button to return to the original mode.

Adjusting speaker delay time (DELAY)

The timing when the sound of each speaker reaches the listening position depends on speaker installation and the size of the car. Adjust the delay time of each speaker so that the sound of all speakers reach the listening position at the same time as the sound from the front speakers.

- The initial value is [0 ms].
 - A speaker that was turned off in the Section “Turning speakers on or off (SP-SEL)” is not displayed.
1. Press and hold the [ADJ] button for 1 second or longer to enter adjust mode.
 2. Press the [◀] or [▶] button to change to the [DELAY **E**] display.
 3. Press the [ENT] button to display the adjustment item.
 4. Press the [◀] or [▶] button to select the speaker to adjust.
 - **CTR-SP**: centre speaker
 - **SRD-SP**: rear (surround) speaker
 5. Turn the [ROTARY] knob clockwise or counterclockwise to select the delay time.
 - The [CTR-SP] adjustment range is 0 to 5 ms.
 - The [SRD-SP] adjustment range is 0 to 15 ms.
 6. Press the [ADJ] button to return to the original mode.

Setting the Dolby Digital functions (Dolby D)

● Dynamic range compression function (D-RANGE):

This function compresses the dynamic range of Dolby Digital to maintain low level sounds such as actor conversation and suppress loud sound volumes.

These functions are only available on Dolby Digital DVD discs.

1. Press and hold the [ADJ] button for 1 second or longer to enter adjust mode.
2. Press the [◀] or [▶] button to change to the [Dolby D] display.

Setting Acoustic Features

3. Turn the **[ROTARY]** knob clockwise or counterclockwise to select the value from **[MAX]**, **[STD]** or **[MIN]**.
 - The initial value is **[MAX]**.
 - **MAX**: maximum dynamic range mode of the original source
 - **STD**: recommended mode for standard listening
 - **MIN**: the most compressed dynamic range mode that renders even low sounds easy to hear.
4. Press the **[ADJ]** button to return to the original mode.

MUSIC Mode Fine Adjustments (PL II CONT)

When MUSIC Mode has been selected on the PL II menu, finer adjustments can be made when desired.

CTR WIDTH is not available when centre speaker is turned off in the section "Turning speakers on or off (SP-SEL)".

1. Press and hold the **[ADJ]** button for 1 second or longer to enter adjust mode.
2. Press the **[◀◀]** or **[▶▶]** button to show the **[PL II CONT 3]** display.
3. Press the **[ENT]** button to display the adjustment item.
4. Press the **[◀◀]** or **[▶▶]** button to select the item.

● PANORAMA (Y or N):

Selecting PANORAMA mode will extend the front sound field image to the rear. If surround effect does not seem to be presented sufficiently, select the setting position **[Y]**.

- The initial setting is **[N]**.

● DIMENSION (0 to 6):

Selecting DIMENSION mode will shift the sound field image to the front or the rear. If the balance of the sound field image is too much pulled towards the front or rear, the balance front/rear can be corrected.

The adjusting value 3 is the centre position. The range of 3 to 0 shifts the balance front/rear to the rear. The range of 3 to 6 shifts the balance front/rear to the front.

- The initial value is **[3]**.

● CTR WIDTH (0 to 7):

Selecting CTR WIDTH mode will adjust the localization of the centre channel between the centre speaker and the front speaker L/R. Distributing the centre channel sound to the right and left will increase the integrated sound field image, providing you with a natural spatial feeling of sound.

Setting to the value 0 will produce the centre sound with the centre speaker.

Setting to the value 7 will distribute the centre sound to the front speaker L/R as the existing stereo sound does.

- The initial value is **[3]**.

5. Turn the **[ROTARY]** knob clockwise or counterclockwise to adjust the value.
6. Press the **[ADJ]** button to return to the original mode.

Setting Auto Volume

1. Press and hold the **[ADJ]** button for 1 second or longer and enter adjust mode.
2. Press the **[◀◀]** or **[▶▶]** button to select the **[CALIBRATE 3]**.
3. Press the **[ENT]** button and **[START 3]** is displayed.
4. Keep driving speed 50km/h and press the **[ENT]** button.
5. "CALIBRATION" is flash for 2 seconds in display.
6. If calibration is successful display indicate "SUCCESSFUL" and sound long beep, or if calibration is not successful display indicate "FAILED" and sound 2 times a short beep.
7. If you failed, repeat steps 3 to 6.

Note:

- When installing this device or transferring it into another vehicle, for sake of safety, always have this work done by the store of purchase or your nearest Clarion dealer. Installation requires specialized techniques and experience.

Setting Auto Volume sensitivity

1. Press and hold the **[ADJ]** button for 1 second or longer and enter adjust mode.
2. Press the **[◀◀]** or **[▶▶]** button to select the **[A-VOL SENS]**
3. Turn the **[ROTARY]** knob clockwise or counterclockwise to make the adjustment.
The adjustment steps are below 6 steps, Off → Low → M-L → Mid → M-H → High.

6. WIRING TECHNIQUES

Name of Parts

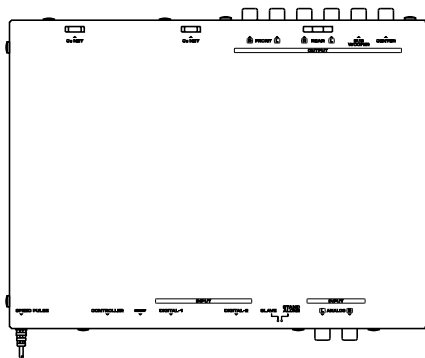
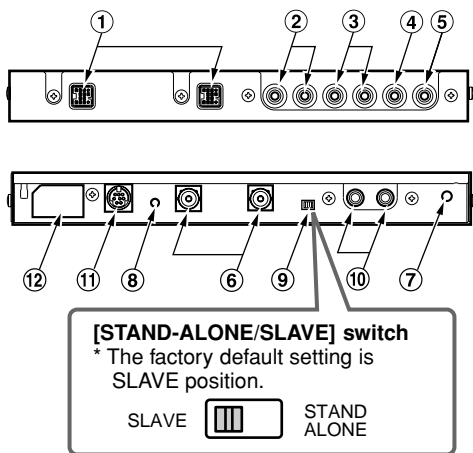

Speed pulse cord

Connect to speed pulse signal cord of the vehicle. If you already own DXZ748RMP and use it with Auto Volume, disconnect the speed pulse cord and replace with the speed pulse cord provided with this unit, then perform calibration.

- ① **CeNET connectors**
Connect to centre unit using CeNET cable.
- ② **Front RCA output connectors**
Connect to external power amplifier using RCA pin cable.
- ③ **Rear RCA output connectors**
Connect to external power amplifier using RCA pin cable.
- ④ **Sub-woofer RCA output connectors**
Connect to external power amplifier using RCA pin cable.
- ⑤ **Centre speaker RCA output connectors**
Connect to external power amplifier using RCA pin cable.
- ⑥ **Digital input connector**
Connect to DVD/CD changer using optical digital cable (sold separately or included).
* Connect to black connector side
- ⑦ **Cable clip hole**
Insert cable clip to hold optical digital cable in place.
- ⑧ **RESET switch**
Press to reset circuitry if no sound is produced.

Note:

- Be sure the CeNET cable is connected when pressing the [RESET] switch.

Use When Connecting Optional Control Unit (DVC923)

- ⑨ **[STAND-ALONE / SLAVE] switch**
 - Set to STAND ALONE when connecting a control unit.
 - Leave at SLAVE position when no control unit is connected.
- ⑩ **Analog input connectors (RCA)**
Connect to centre unit's RCA 2ch output.
Note:
 - The following are enabled only when a control unit is connected.
- ⑪ **Control unit 8P mini DIN plug**
Connect to control unit.
- ⑫ **Control unit power connector**
Connect control unit's power cable here.
* Leave tape in place when not in use.

How to Wire This Unit

Perform the settings and connections in the order indicated by the drawing below.

⚠ CAUTION

Throughout the process of wiring this unit, disconnect the negative (-) terminal of your automobile's battery, and leave it disconnected until completely finished. Handling wires while the terminal is connected could result in dangerous electrical shock or injury if an accidental short circuit should occur.

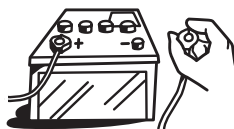

1 CeNET Cable

- To connect a CeNET cable, hold it with the connector facing as shown, and insert securely.
- When disconnecting a CeNET cable, grasp the slide cap and squeeze gently.

2 Optical Digital Cable

- Insert the black connector securely into the digital signal input connector until it locks. The cable clip can be used to secure up to two optical digital cables.
- When disconnecting an optical digital cable, squeeze the tabs at the right and left sides of the connector, and pull gently.

Note:

- The optical digital cable should not be bent with a gentle arc radius of 1.5 cm or less. If it is bent sharper than this, the performance of the cable will be greatly reduced and the cable may be damaged.

3 RCA Pin Cable

- When connecting an RCA pin cable, be sure to confirm the source of the connection first.

4 [RESET] switch

- Following completion of wiring, press the [RESET] switch to return to default settings.

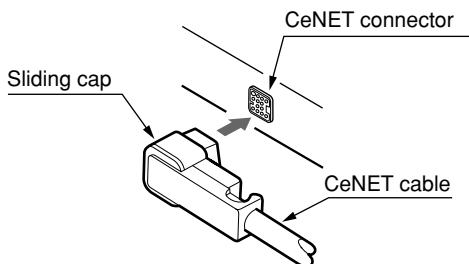

Note:

- Route the CeNET cable with plenty of extra room so that the connector will not become disconnected accidentally.

Optical Digital cable (black connection)

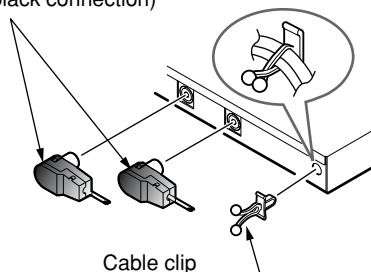

Squeeze right/left tabs

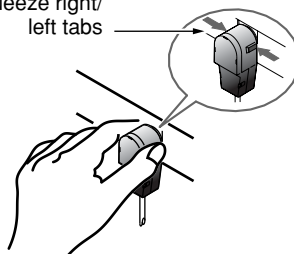

Note:

- Always turn the main [POWER] switch [OFF] before connecting or disconnecting digital fiber-optic cables.

7. INSTALLATION

Installation Precautions

CAUTION!

- Install correctly, using only the screws supplied as accessories. Using other screws may result in damage or injury.

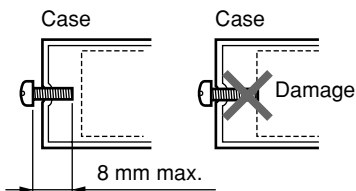

Installation Example (for installation beneath seat)

1. Use the supplied screws (M4x8) to attach the accessory mounting bracket to the sides of the unit.
 - The main unit's case has been provided with 3 screw holes on either side. Select the screw holes required for your installation conditions.
2. Position the unit on the floor mat, then mark and open holes in the floor mat so they are aligned with the mounting bracket's holes.
3. Press the accessory canoe clips from the underside upward through the mat and into the mounting bracket holes.

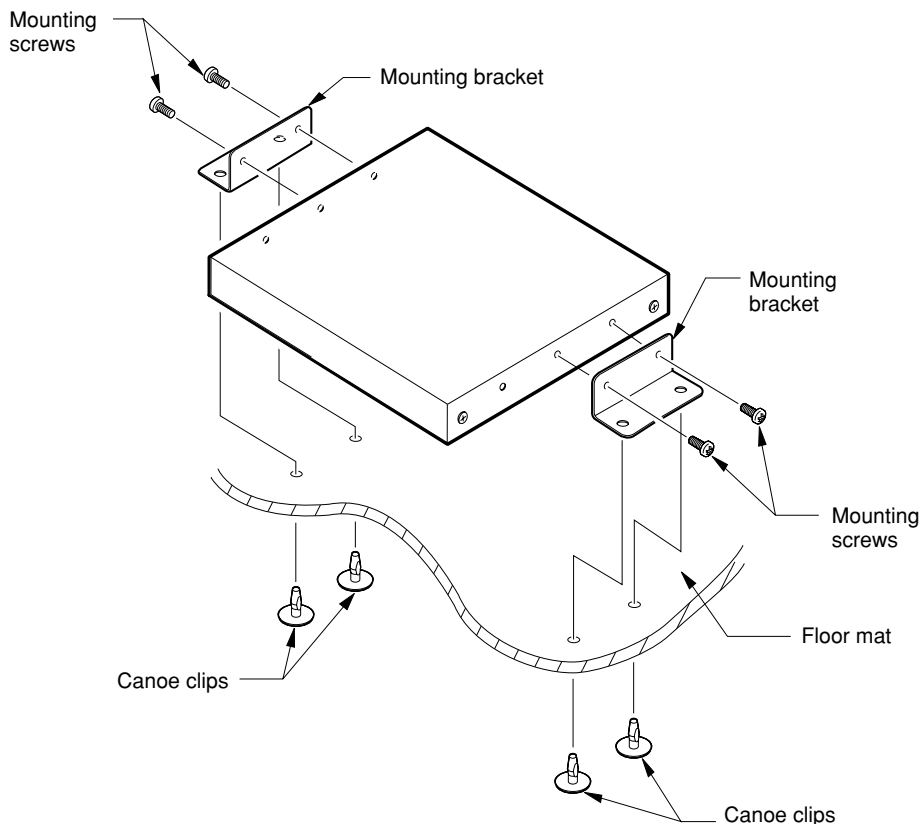

8. SYSTEM EXPANSION

Refer to the Owner's manual for the DVC923 for an example of the stand-alone system connections.

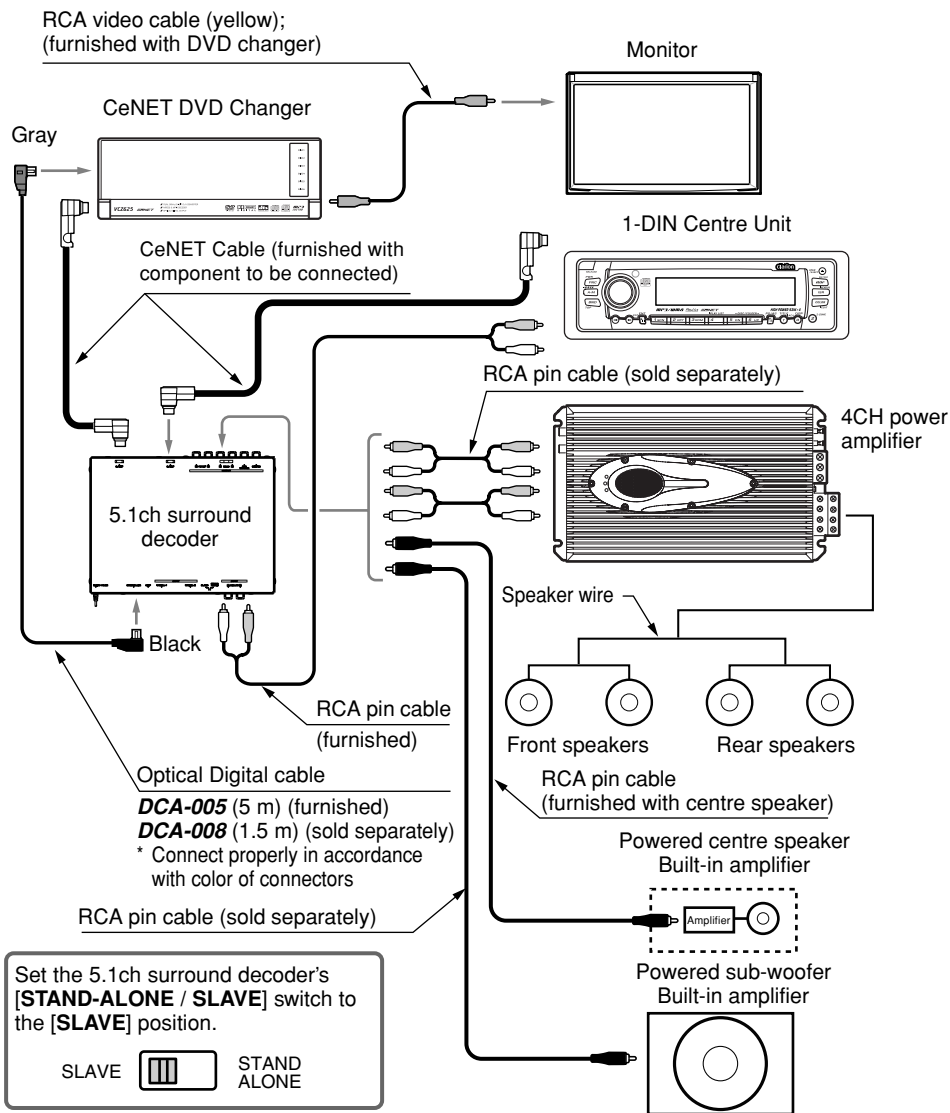

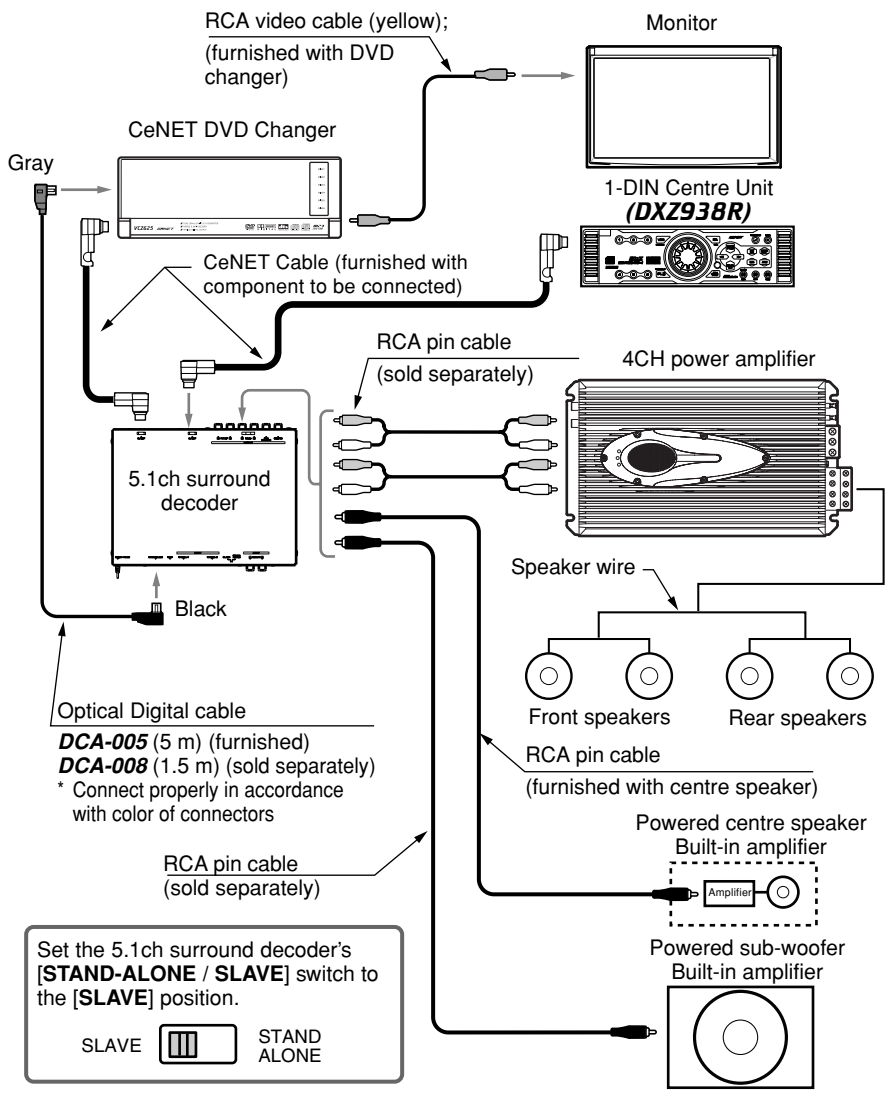

9. IN CASE OF DIFFICULTY

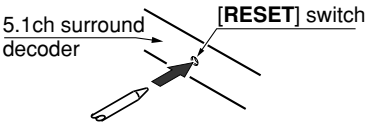
Problem	Cause	Measure
Nothing happens when buttons are pressed.	The microprocessor has malfunctioned due to noise, etc.	Use a narrow stick to press the [RESET] switch on the side of the 5.1ch surround decoder. Note that when the [RESET] switch is pressed, all titles and other data placed in memory will be erased.  <p>The diagram shows a perspective view of a rectangular component labeled '5.1ch surround decoder'. On its right side, there is a small, dark, rectangular button labeled '[RESET] switch'. A thin, light-colored stick is shown pressing down on the top surface of this switch. Arrows point from the text labels to their respective parts in the diagram.</p>
No sound produced from centre speaker	The source being played is a 2-ch source lacking a centre channel (music CD, linear PCM stereo, etc.).	Either choose one of the Dolby Pro Logic II modes, or set DSF effect to ON (see P. 7).
	Dolby Pro Logic II or DSF is set to OFF.	
	The centre speaker setting is OFF (default setting is ON).	Set centre speaker (SP-SEL) to ON (see P. 8)